

Phase-Noise Calculation Overview

When calculating the phase noise of a system there are many considerations. The following illustrates phase noise calculation of a system and the effects of correlated components versus uncorrelated components. Following these calculations there is an illustration showing consideration of absolute power levels and how they affect the phase noise of a system. Let us assume the phase noise for each component at a single offset frequency, say 100 kHz is the following in dBc/Hz:

Phase Noise of each Component

Source	S1=-150	2 nd Doubler D2=-155
1 st Doubler	D1=-155	3 rd Doubler D3=-155
1 st Amp.	A1=-165	2 nd Amp. A2=-165

We will start off with a doubler and amplifier:

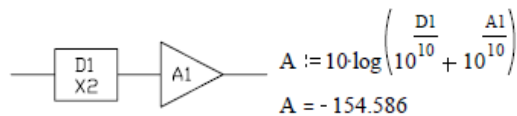

If we have a component preceding a doubler or any multiplier, its phase noise will be degraded by 20 log of the multiplication factor.

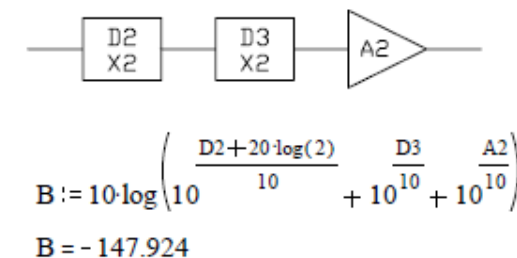

Let's consider a mixer. If we have two *uncorrelated* sources with the same phase noise characteristics conditioned by these components and fed into a mixer the calculations and result would be as follows:

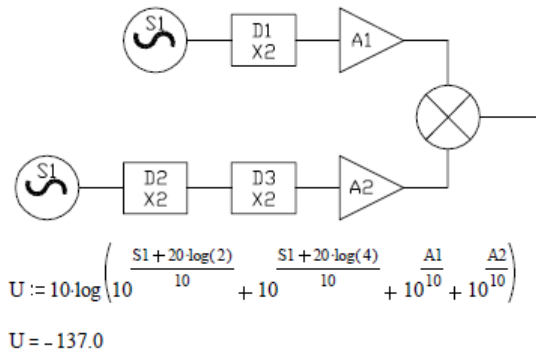

When the output of a single source is split, conditioned and mixed it is considered correlated. This would also be true if the two sources above were phase locked to each other. The calculations for the source would be *correlated* while the other components are not. The result would be higher phase noise.

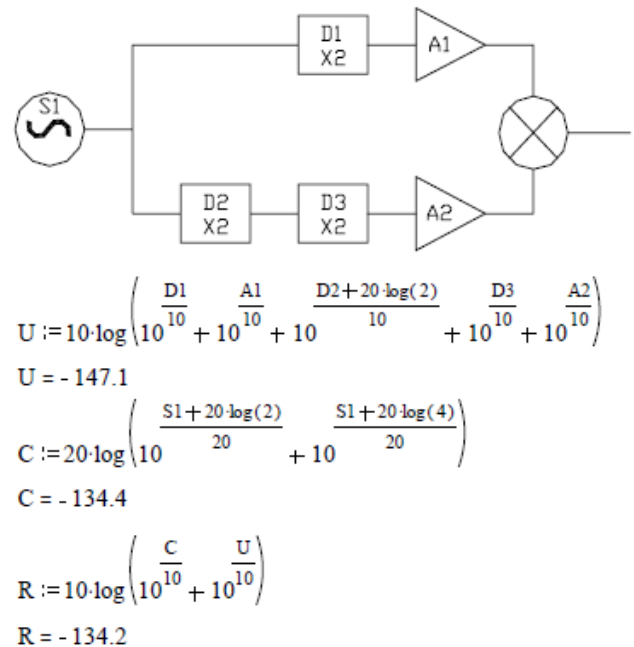

One can also conclude from this that the phase noise of a doubler made by splitting a source and then combining it in a mixer will be the same as using a passive doubler.

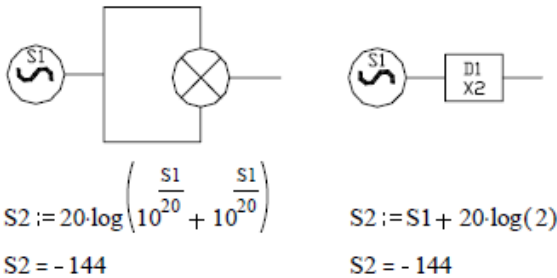

Thermal Noise Floor

If the phase noise measurement of a component

Pin := 15
D2 := 3
D3 := -9
A2 := 11

$$N_{\text{floor}} := 10 \cdot \log \left(10^{\frac{-174 - \text{Pin} + 20 \cdot \log(4)}{10}} + 10^{\frac{-174 - \text{D2} + 20 \cdot \log(2)}{10}} + 10^{\frac{-174 - \text{D3}}{10}} + 10^{\frac{-174 - \text{A2}}{10}} \right)$$

$$N_{\text{floor}} = -163.8 \text{ dBc/Hz}$$

is made at the same power levels that will exist in the system the thermal noise floor is already in the result. If the data is recorded at much higher power levels than components will experience in the system or if the engineer would like to know what the power levels must be to maintain a particular phase noise result then the thermal noise floor must be a consideration. The thermal noise floor or kTB is ~-174 dBm/Hz. This is based on Boltzmann's constant, the temperature, and the bandwidth of the signal.

$$kTB := 10 \cdot \log \left[1.381 \cdot 10^{-23} \cdot (273 + 25) \cdot 1000 \right]$$

$$kTB = -174$$

Thermal noise is specified in dBm. If the phase noise of a component comes close to this power level it will be degraded and there is no method to correct the situation short of filtering for phase noise. The same rules for calculating correlated and uncorrelated components

apply as before so let us consider the performance of the following cascade.

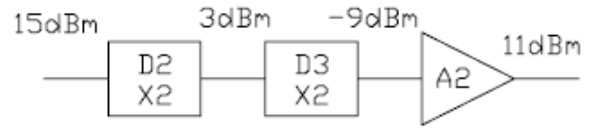

Therefore if the source in this system were ideal it would have a phase noise of -189 dBc/Hz (-174-15). Allowing the power level to drop significantly degrades the system noise performance.

Conclusion

When calculating the phase noise of a system one must pay close attention to power levels and precisely how the signal is used and reused.